

ELECTRONICS ENGINEERING

Analog Circuits

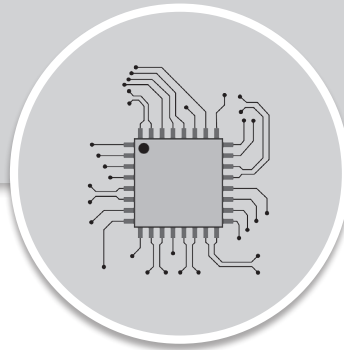

Comprehensive Theory
with Solved Examples and Practice Questions





MADE EASY Publications Pvt. Ltd.

Corporate Office: 44-A/4, Kalu Sarai (Near Hauz Khas Metro Station), New Delhi-110016 | **Ph. :** 9021300500

Email : infomep@madeeasy.in | **Web :** www.madeeasypublications.org

Analog Circuits

Copyright © by MADE EASY Publications Pvt. Ltd.
All rights are reserved. No part of this publication may be reproduced, stored in or introduced into a retrieval system, or transmitted in any form or by any means (electronic, mechanical, photo-copying, recording or otherwise), without the prior written permission of the above mentioned publisher of this book.

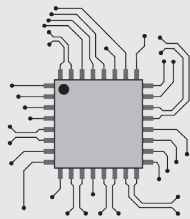

MADE EASY Publications Pvt. Ltd. has taken due care in collecting the data and providing the solutions, before publishing this book. In spite of this, if any inaccuracy or printing error occurs then **MADE EASY Publications Pvt. Ltd.** owes no responsibility. We will be grateful if you could point out any such error. Your suggestions will be appreciated.

EDITIONS

First Edition : 2015
Second Edition : 2016
Third Edition : 2017
Fourth Edition : 2018
Fifth Edition : 2019
Sixth Edition : 2020
Seventh Edition : 2021
Eighth Edition : 2022
Ninth Edition : 2023

Tenth Edition : 2024

CONTENTS

Analog Circuits

CHAPTER 1

Diode Circuits	4-77
1.1 Introduction	4
1.2 Diode Circuits : DC Analysis and Models.....	4
1.3 Diode Logic Gates	10
1.4 Diode Equivalent Circuits	12
1.5 DC Power Supply	15
1.6 Rectifier	16
1.7 Half-wave Rectifier	16
1.8 Centre-Tapped Full-wave Rectifier	25
1.9 Bridge Rectifier	32
1.10 Comparison of Rectifier Circuits with Resistive Load.....	35
1.11 Filter.....	35
1.12 Inductor Filter	36
1.13 Capacitor Filter	37
1.14 LC Filter (L-Section Filter)	40
1.15 CLC Filter (II-Section Filter).....	43
1.16 Voltage Regulators.....	44
1.17 Zener Diode Shunt Regulator	45
1.18 Op-amp Controlled Series Regulator	47
1.19 Transistorized Series Regulator	48
1.20 Fixed Voltage IC Regulators	51
1.21 Wave Shaping	52
1.22 Clipper	52
1.23 Linear Wave Shaping	59
1.24 Clamper.....	65
1.25 Voltage Multiplier	69
<i>Objective Brain Teasers</i>	71
<i>Conventional Brain Teasers</i>	75

CHAPTER 2

Bipolar Junction Transistors-Characteristics and Biasing	78-97
2.1 Introduction	78
2.2 Transistors Current Components	80
2.3 Early Effect.....	84
2.4 BJT Configuration	85
2.5 The Common Base Configuration	86
2.6 The Common-Emitter Configuration	89
2.7 The Common-Collector Configuration.....	91
<i>Objective Brain Teasers</i>	92
<i>Conventional Brain Teasers</i>	95

CHAPTER 3

Transistor Biasing and Thermal Stabilization	98-131
3.1 Introduction	98
3.2 The Operating Point	98
3.3 Instability in Collector Current.....	100
3.4 BJT Biasing	103
3.5 Fixed Bias Circuit.....	104
3.6 Collector to Base Bias Circuit.....	105
3.7 Self-Bias, Emitter Bias, or Voltage-Divider Bias.....	106
3.8 Bias Compensation	110
3.9 Thermal Runaway.....	112
3.10 BJT Biasing in Integrated Circuits (ICs).....	116
3.11 Constant Current Source (Basic Current Mirror).....	117
3.12 Widlar Current Source.....	119
3.13 Current Repeaters.....	121
3.14 Wilson Current Source	123
<i>Objective Brain Teasers</i>	124
<i>Conventional Brain Teasers</i>	127

CHAPTER 4

BJT as an Amplifier 132-172

4.1 Introduction 132

4.2 Graphical Analysis of BJT Amplifier..... 133

4.3 Transistor Hybrid Model..... 134

4.4 Analysis of Transistor Amplifier
Circuit Using h-Parameters 136

4.5 Small Signal Hybrid- Π Equivalent Circuit of BJT 141

4.6 Hybrid- Π -Equivalent Circuit,
by Considering Early Effect 143

4.7 Basic Transistor Amplifier Configurations..... 144

4.8 Common-Emitter Amplifiers 145

4.9 Common-Collector (Emitter-Follower) Amplifier..... 153

4.10 Common-Base Amplifier..... 158

4.11 Multistage Amplifiers..... 160

Objective Brain Teasers..... 164

Conventional Brain Teasers..... 167

CHAPTER 5

Basic FET Amplifiers 173-194

5.1 Introduction 173

5.2 The Common-Source Amplifier..... 173

5.3 Common-Drain (Source Follower) Amplifier 179

5.4 The Common-Gate Configuration..... 183

Objective Brain Teasers..... 189

Conventional Brain Teasers..... 192

CHAPTER 6

Frequency Response 195-225

6.1 Introduction 195

6.2 Amplifier Frequency Response..... 195

6.3 Miller's Theorem..... 202

6.4 Frequency Response : BJT 204

6.5 High Frequency Response of Common-Emitter
and Common-Source Circuits..... 209

6.6 High Frequency Response of Common-Base..... 213

6.7 High Frequency Response of Emitter..... 216

Objective Brain Teasers..... 219

Conventional Brain Teasers..... 222

CHAPTER 7

Differential Amplifiers.....226-238

7.1 Introduction 226

7.2 The Differential Amplifier 226

7.3 Basic BJT Differential Amplifier 227

7.4 FET Differential Amplifiers..... 232

7.5 Constant Current-Bias..... 233

7.6 Level Translator..... 236

Objective Brain Teasers..... 237

CHAPTER 8

Feedback Amplifiers 239-259

8.1 Introduction 239

8.2 Basic Feedback Concepts 239

8.3 General Block Diagram of Feedback Amplifier 243

8.4 Four Basic Feedback Topologies 246

8.5 Series-Shunt Configuration 246

8.6 Shunt-Series Configuration 249

8.7 Series-Series Configuration..... 250

8.8 Shunt-Shunt Configuration 251

8.9 Summary of Results..... 252

Objective Brain Teasers..... 255

Conventional Brain Teasers..... 258

CHAPTER 9

Large Signal Amplifier.....260-279

9.1 Introduction 260

9.2 Power Amplifier..... 260

9.3 Classification of Power Amplifiers 261

9.4	Direct Coupled Class-A Amplifier	262
9.5	Class-A Transformer Coupled Amplifier	264
9.6	Transformer Coupled Class-B Push Pull Amplifier	268
9.7	Cross-Over Distortion	271
9.8	Class-AB Push-Pull Amplifier	271
9.9	Class-A Push-Pull Amplifier	272
9.10	Transformerless Class-B Push-Pull Amplifier.....	273
9.11	Class-C Power Amplifier	274
9.12	Class-D Amplifiers	275
9.13	Class-S Power Amplifier.....	276
	<i>Objective Brain Teasers</i>	277

CHAPTER 10

Operational Amplifier..... 280-322

10.1	Introduction.....	280
10.2	Block Diagram Representation of A Typical Op-Amp.....	280
10.3	Schematic Symbol	281
10.4	Operational Amplifier Characteristics	281
10.5	DC Characteristics.....	282
10.6	AC Characteristics	284
10.7	Characteristics of Ideal Op-Amp.....	287
10.8	Ideal Voltage Transfer Curve	287
10.9	Inverting Amplifier	288
10.10	Summing Amplifier	293
10.11	Non-inverting Amplifier	295
10.12	Voltage Follower	297
10.13	Current-to-Voltage Converter	298
10.14	Voltage-to-Current Converter	299
10.15	Differential Amplifier	299
10.16	Integrator and Differentiator	302
10.17	Instrumentation Amplifier	304

10.18	Log Amplifier	306
10.19	Antilog or Exponential Amplifier.....	308
10.20	Analog Multiplier IC's (Modulator).....	309
10.21	Analog Divider IC's (De-Modulator)	309
10.22	Precision Diode.....	310
10.23	Half-Wave Rectifier	311
10.24	Full-Wave Rectifier	312
	<i>Objective Brain Teasers</i>	313
	<i>Conventional Brain Teasers</i>	318

CHAPTER 11

Signal Generators and Waveform Shaping Circuits..... 323-361

11.1	Introduction.....	323
11.2	Oscillators	323
11.3	The Phase-Shift Oscillator.....	326
11.4	Wien Bridge Oscillator.....	332
11.5	LC Oscillators	335
11.6	Crystal Oscillators.....	340
11.7	Comparison between LC Oscillators and Crystal Oscillators.....	342
11.8	Comparator	343
11.9	Zero-Crossing Detector	344
11.10	Sample-And-Hold Circuits.....	346
11.11	Basic Inverting Schmitt Trigger.....	347
11.12	Schmitt Trigger Oscillator	349
11.13	Monostable Multivibrator.....	351
11.14	The 555 Circuit	352
	<i>Objective Brain Teasers</i>	359



ANALOG CIRCUITS

Introduction to Analog Circuits

After studying the basic electronic devices and their characteristics, now we shall deal with more complex analog circuits, of which amplifiers is a very significant category. We shall start our analysis with applications of diode, a very fundamental component, in various circuit configurations such as clipper, clamper, regulator etc. Further, we shall proceed to applications of BJT and FET, particularly as an amplifier.

The other complex analog circuits, including circuits that form operational amplifiers, are also part of this book. These circuits are composed of fundamental configurations, such as differential amplifier, constant-current source, active load, and output stage, all of which have been discussed in detail.

The major emphasis throughout the book is on developing the reader's understanding for analyzing and designing various fundamental circuits, which are always an integral part of various competitive examinations. Throughout the book, a very sequential and comprehensive approach has been used, so that a beginner can also utilize the book in very efficient manner.

Prelude to Analog Circuits

ELECTRONICS

Electronics is defined as the science of motion of charges in a gas, vacuum, or semiconductor. Note that the charge motion in a metal is excluded from this definition.

This definition was used early in the 20th century to separate the field of electrical engineering, which dealt with motors, generators, and wire communications, from the new field of electronic engineering, which at that time dealt with the vacuum tubes.

ELECTRONIC CIRCUITS

A circuit which consists of at least one electronic device (e.g. amplifier, rectifier, oscillator etc.) is known as an electronic circuit.

In most of the electronic circuits there are two inputs. One input is from power supply which provides dc voltages and currents to establish proper biasing for transistors. The second input is a signal that can be amplified by the circuit. Although the output signal can be larger than the input signal but the output power can never exceed the dc input power. Therefore, the magnitude of dc power supply is one limitation to the output signal response.

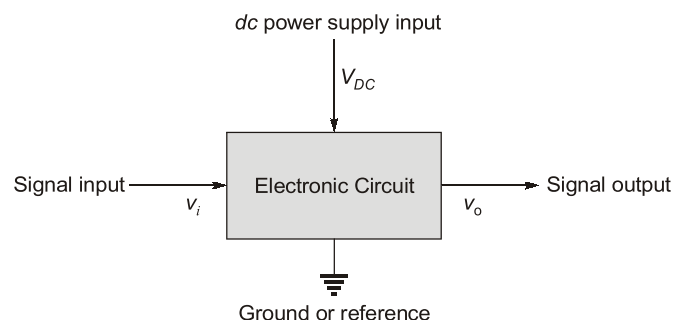

ANALOG AND DIGITAL SIGNALS

- The voltage signal shown graphically in Figure (a) is called an analog signal. The magnitude of an analog signal may have any value ; that is, the amplitude may vary continuously with respect to time. Electronic circuits that process such signals are called analog circuits.

- An alternative signal is at one of two distinct levels and is called a digital signal (shown in figure (b)). Because the digital signal has discrete values, it is said to be quantized. Electronic circuits that process digital signals are called digital circuits.

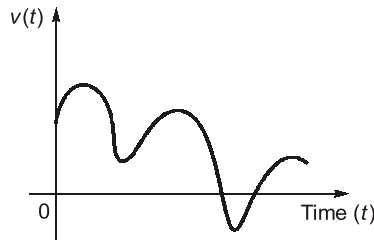

Figure (a)

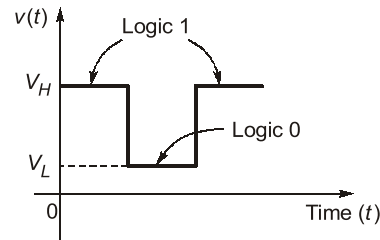

Figure (b)

Advantages of Analog Circuits

- Majority of signals in the “real world” are analog; so these signals can be directly processed in analog circuits whereas digital processing requires analog to digital and digital to analog conversion.
- Analog circuits can be designed to operate even at higher power levels.

Disadvantages of Analog Circuits

- Loss of information due to effect of noise is more.
- Lower quality signals than digital signals.

Advantages of Digital Circuits

- In digital circuits effect of noise is less.
- Digital circuits can be programmed.
- Digital data can be stored.

Disadvantages of Digital Circuits

- Expensive.
- Operate on digital signals only.
- High operational power is required.



Diode Circuits

1.1 INTRODUCTION

The simplest and most fundamental non-linear circuit element is a diode. Just like a resistor, the diode has two terminals; but unlike the resistor which has a linear (straight-line) relationship between the current flowing through it and the voltage appearing across it, the diode has non-linear i-v characteristics. The analysis of non-linear electronic circuits is not as straight-forward as the analysis of linear electric circuits. However, there are electronic functions that can be implemented only by non-linear circuits. Examples include the generation of dc voltages from sinusoidal voltages and the implementation of logic functions.

1.2 DIODE CIRCUITS : DC ANALYSIS AND MODELS

Mathematical relationships, or *models*, that describes the current-voltage characteristics of electrical elements allow us to analyze and design circuits without having to fabricate and test them in the laboratory. An example is Ohm's law, which describes the properties of a resistor. In this section, we will develop the dc analysis and modelling techniques of diode circuits.

To begin to understand diode circuits, consider an *ideal diode*. It is a two terminal device having the circuit symbol and the i-v characteristics shown in figure below.

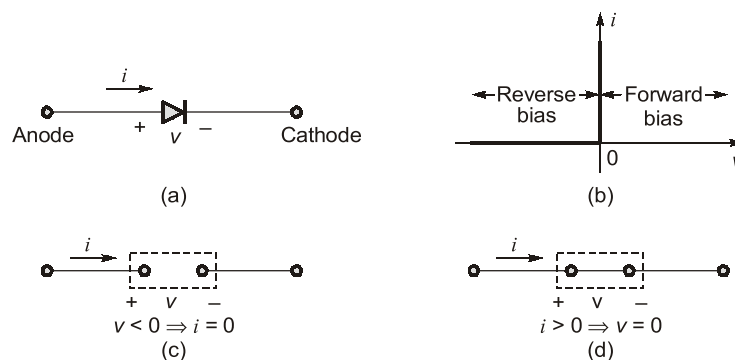

Figure: The ideal diode: (a) Diode circuit symbol; (b) i-v characteristics; (c) Equivalent circuit in the reverse direction (d) Equivalent circuit in the forward direction.

The terminal characteristics of the ideal diode can be interpreted to follows:

- If a negative voltage is applied to the diode, no current flows and the diode behaves as an **open circuit** [as shown in Figure (c)]. Diodes operated in this mode are said to be **reverse biased**.
- On the other hand, if a positive current is applied to the ideal diode, zero voltage drop appears across the diode. In other words the ideal diode behaves as a **short circuit** in the forward direction [as shown in Figure (d)]. Diodes operated in this mode are said to be **forward biased**

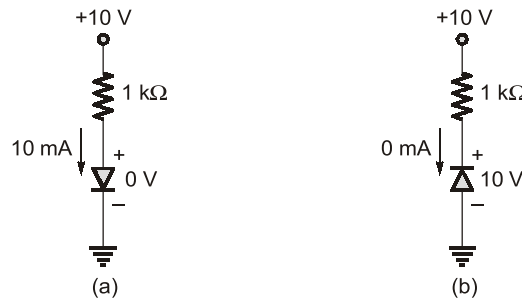

Figure: The two modes of operation of ideal diodes and the use of external circuit to limit (a) the forward current and (b) the reverse voltage

From the above description it should be noted that the external circuit must be designed to limit the forward current through a conducting diode, and the reverse voltage across a cut-off diode to predetermined values. Above figure shows two diode circuits that illustrate this point. In the circuit of Figure (a) the diode is obviously conducting. Thus its voltage drop will be zero, and the current through it will be determined by the +10 V supply and the 1 kΩ resistor as 10 mA. The diode in the circuit is obviously cut-off, and thus its current will be zero which in turn means that the entire 10 V supply will appear as reverse bias across the diode.

For practical diodes, $i-v$ characteristics is shown in figure. When the practical diode characteristics are compared to the ideal diode characteristics, one considers the only major difference is that, during forward biased condition. Voltage drop across the diode is 0.7 V (for silicon diode) rather than 0 V, and during reverse biased condition current flows across the diode is approximately I_o (reverse saturation current in μA) rather than 0 A.

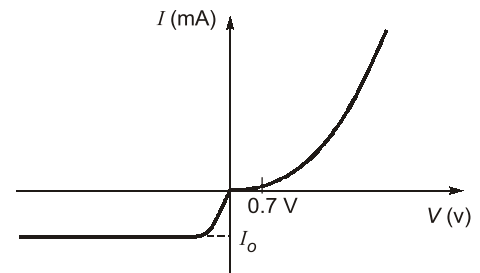

Figure : Practical characteristics of diode

1.2.1 Load-Line Analysis

The circuit of below figure is the simplest of diode configurations. Solving the circuit is all about finding the current and voltage levels that will satisfy both the characteristics of the diode and the chosen network parameters at the same time.

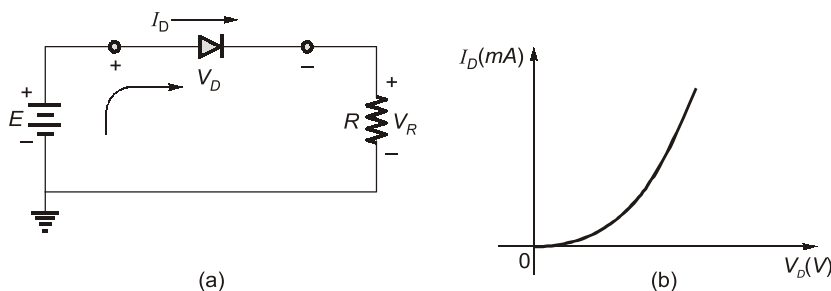

Figure: Series diode configuration (a) Circuit (b) Characteristics

In below figure the diode characteristics are placed on the same set of axis as a straight line defined by the parameters of the network. The straight line is called a **load line** because the intersection of the vertical axis is defined by the applied load R . The analysis to follow is therefore called **load-line analysis**. The intersection of the two curves will define the solution for the network and define the current and the voltage levels for the network.

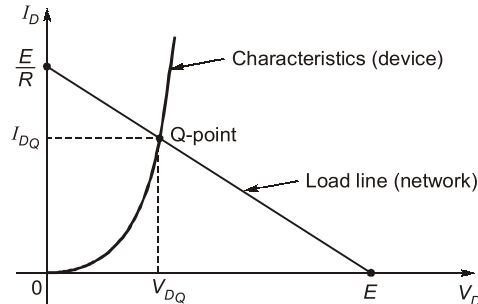

Figure: Drawing the load line and finding the point of operation

- A straight line drawn between the two points will define the load line as depicted in Figure. Change the level of R (the load), which will lead to the change in the intersection on the vertical axis. This will be resulted into the change in the slope of the load line and different point of intersection between the load line and the device characteristics.
- Now, we have a load line defined by the network and a characteristic curve defined by the device. The point of intersection between the two is the point of operation for this circuit.
- By simply drawing a line down to the horizontal axis, we can determine the diode voltage V_{DQ} , whereas a horizontal line from the point of intersection to the vertical axis will provide the level of I_{DQ} . The point of operation is usually called the **quiescent point** (abbreviated "**Q-point**") to reflect its "still, unmoving" qualities as defined by a dc network.
- The solution obtained at the intersection of the two curves is the same as would be obtained by a simultaneous mathematical solution of

$$I_D = \frac{E}{R} - \frac{V_D}{R} \quad \text{[Derived from equation 1.1]}$$

$$\text{and} \quad I_D = I_0(e^{V_D/nV_T} - 1) \quad \text{[Diode equation]}$$

1.2.2 Series Diode Configuration

The approximate models will now be used to investigate a number of series diode configurations with dc inputs. This will establish a foundation in diode analysis that will carry over into the sections and chapters to follow. The procedure described below, can in fact be applied to the networks with any number of diodes in variety of configurations.

- For each configuration, firstly the state of each diode must be determined. Which diodes are "**on**" and which are "**off**"? Once determined, the appropriate equivalent can be substituted and the remaining parameters of the network can be determined.
- For the conduction region the only difference between the silicon diode and the ideal diode is the vertical shift in the characteristics, which is accounted for in the equivalent model by a dc supply of 0.7 V opposing the direction of forward current through the device. For voltages less than 0.7 V for a silicon diode and 0 V for the ideal diode the resistance is so high compared to the other elements of the network that its equivalent is the open circuit.
- **In general, a diode is in the "on" state if the current established by the applied sources is such that its direction matches that of the arrow in the diode symbol, and $V_D \geq 0$ V for ideal**

diode, $V_D \geq 0.3 \text{ V}$ for germanium diode, $V_D \geq 0.7 \text{ V}$ for silicon diode, and $V_D \geq 1.2 \text{ V}$ for gallium arsenide diode.

The below circuit of will be used to demonstrate the approach described in the above paragraphs.

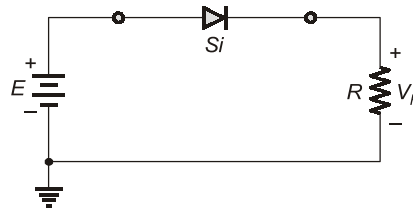

Figure: Series diode configuration

The state of the diode is first determined by mentally replacing the diode with a resistive element as shown in Figure (a). The resulting direction of I is a match with the arrow in the diode symbol, and since $E > V_Y$ (cut-in voltage of diode), the diode is in the “on” state. The network is redrawn as shown in Figure (b) with the appropriate equivalent model for the forward biased silicon diode.

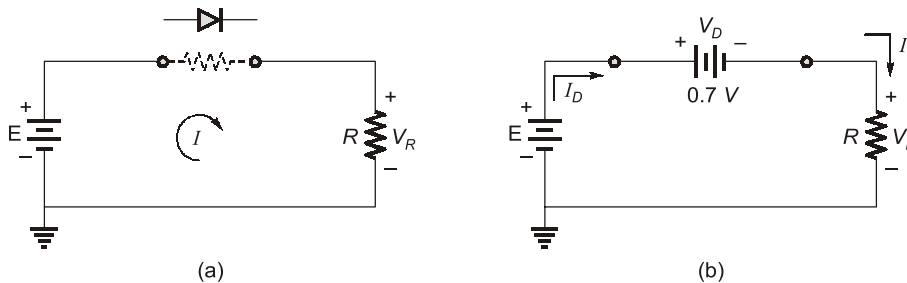

Figure: Series diode circuit analysis in forward bias

Following are the resulting voltage and current levels:

$$\begin{aligned} V_D &= V_Y \\ V_R &= E - V_Y \\ I_D &= I_R = \frac{V_R}{R} \end{aligned} \quad \dots(1.4)$$

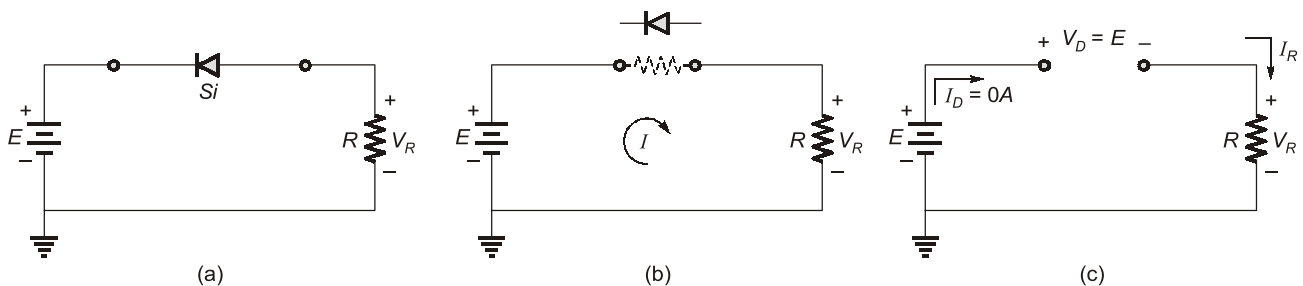

Figure: Series diode circuit analysis in reverse bias

When reverse bias is applied to diode then mentally replace the diode with a resistive element as shown in Figure (b) will reveal that the resulting current direction does not match the arrow in the diode symbol. The diode is in the “off” state, resulting in the equivalent circuit of Figure (c). Due to the open circuit, the diode current is 0 A and the voltage across the resistor R is the following:

$$V_R = I_R R = I_D R = (0 \text{ A}) R = 0 \text{ V}$$

The fact that $V_R = 0 \text{ V}$ will establish E volts across the open circuit defined by Kirchhoff's voltage law. Always keep in mind that under any circumstances i.e. either DC or AC—**Kirchhoff's voltage law must be satisfied!**

EXAMPLE : 1.1

[Single Branch Diode Circuits]

Assuming the diodes to be ideal, find the values of I and V in the circuits shown below:

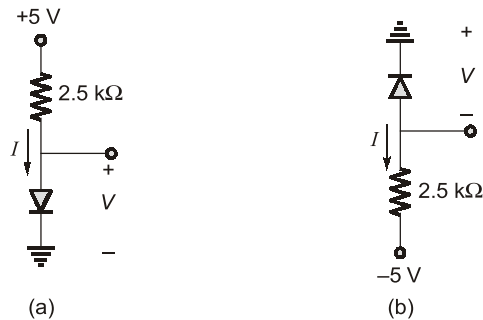
**Solution :**

In Fig. (a) replacing the diode with a resistive element as shown below in **Fig. (i)**:

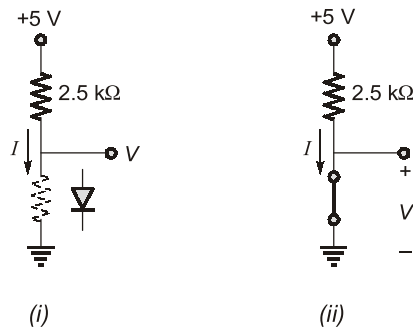

The resulting direction of I is a match with the arrow in the diode symbol, hence the diode is in the “on” state. Now the network can be redrawn as shown in **Fig. (ii)**.

The resulting voltage and current levels are the following:

$$V = 0 \text{ V} \quad [\text{as diode is ideal so } V_Y = 0 \text{ V}]$$

and

$$I = \frac{5-0}{2.5 \text{ k}} = 2 \text{ mA}$$

In Fig. (b) replacing the diode with a resistive element as shown below in **Fig. (iii)**:

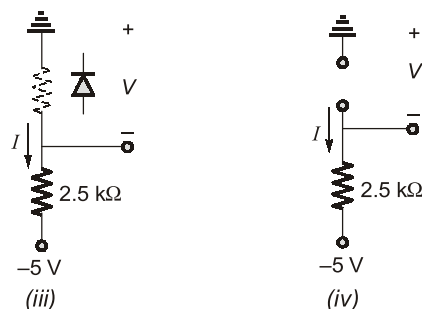

Fig. (iii) reveals that the resulting direction of current I does not match the arrow in the diode symbol. The diode is in the “off” state resulting in the equivalent circuit as shown in **Fig. (iv)**:

Resulting current and voltage can be calculated as below:

$$I = 0 \text{ A} \quad [\text{Since diode is open circuit}]$$

Now applying KVL in the circuit

$$\begin{aligned}
 &V + 2.5I - 5 = 0 \\
 \Rightarrow &V + 2.5 \times 0 - 5 = 0 \\
 \Rightarrow &V = 5 \text{ V}
 \end{aligned}$$

EXAMPLE : 1.2

Assuming diodes to be ideal, find the values of I and V in the following circuit:

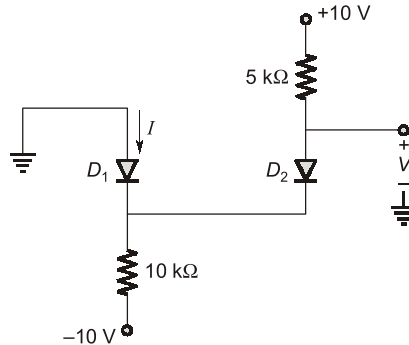

Solution:

If we assume that both diodes are conducting then $V_B = 0 \text{ V}$ and $V = 0 \text{ V}$. The current in D_2 is obtained from

$$I_{D_2} = \frac{10 - 0}{5\text{k}} = 2 \text{ mA}$$

The node equation at B is

$$I + 2 \text{ mA} = \frac{0 - (-10)}{10\text{k}}$$

\Rightarrow

$$I = -1 \text{ mA}$$

$I = -1 \text{ mA}$, is not possible as I does not match with arrow direction of the diode D_1 so our original assumption is not correct. We start again, assuming that D_1 is off and D_2 is on. The current I_{D_2} is given by

$$I_{D_2} = \frac{10 - (-10)}{10\text{k} + 5\text{k}} = 1.33 \text{ mA}$$

and the voltage at node B is, $V_B = -10 + 10\text{k} \times 1.33 \text{ mA} = +3.3 \text{ V}$

Thus D_1 is reverse biased as assumed, and the final result is $I = 0 \text{ A}$ and $V = 3.3 \text{ V}$.

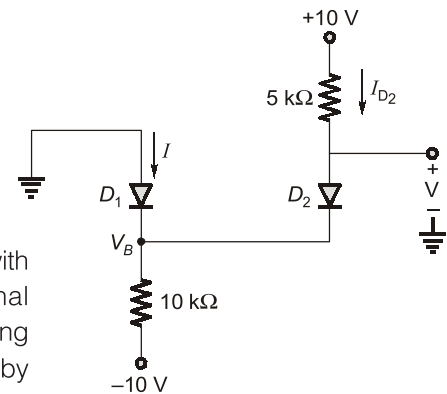

EXAMPLE : 1.3

[Practical diode circuit]

Find I and V for the circuit shown below:

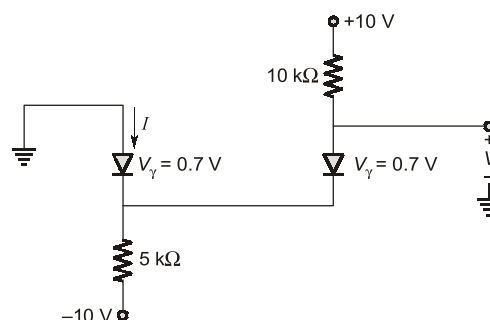



OBJECTIVE BRAIN TEASERS

Q.1 In the circuit shown below the input v_i has positive and negative swings and v_o is the output then

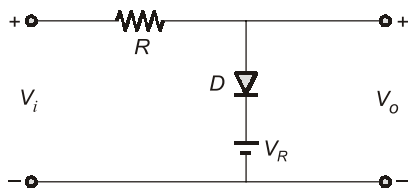

- (a) $v_o = 0$ for negative v_i
- (b) $v_o = V_R$ for positive v_i
- (c) $v_o = V_R$ for $v_i > V_R$
- (d) $v_o = V_R$ for all v_i

Q.2 In the Si diode circuit shown below, a diode current of 6.7 mA is flowing.

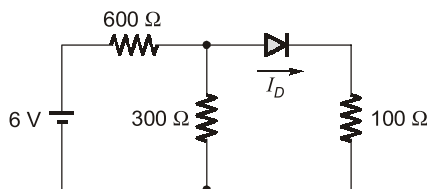

- Assuming diode is ideal one. Its forward resistance and cut-in voltage are
- (a) $2 \Omega, 0.7 \text{ V}$
 - (b) $0 \Omega, 0.7 \text{ V}$
 - (c) $0 \Omega, 0 \text{ V}$
 - (d) $4 \Omega, 0 \text{ V}$

Q.5 Consider the circuit shown in Figure (I). If the diode used here has the V-I characteristic as in Figure (II), then the output waveform v_o is

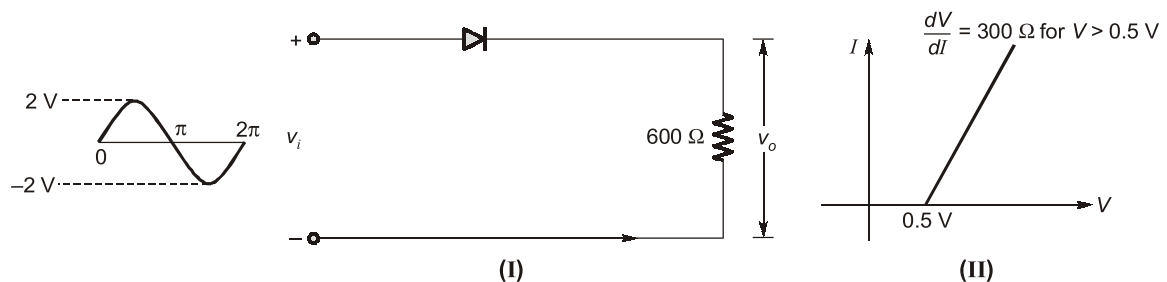

Q.3 In the circuit shown below the Zener voltage $V_{Z1} = V_{Z2} = 5$ volts, $V_Y = 0.6 \text{ V}$, v_o is the output then

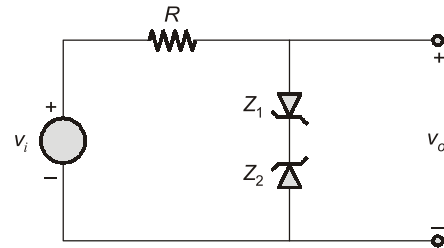

- (a) For $|v_i| \leq 5.6$ volts, $v_o = v_i$
- (b) For $|v_i| \leq 10$ volts, $v_o = v_i$
- (c) For $|v_i| > 5.6$ volts, $v_o = v_i$
- (d) $v_o = 5.6$ volts for all v_i

Q.4 The 6 V Zener diode shown in figure has zero Zener resistance and a knee current of 5 mA. The minimum value of R so that the voltage across it does not fall below 6 V is

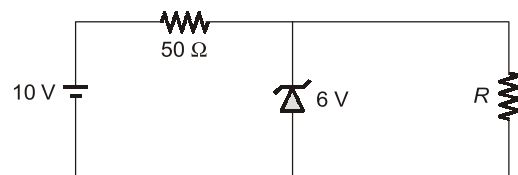

- (a) 1200Ω
- (b) 80Ω
- (c) 50Ω
- (d) 10Ω

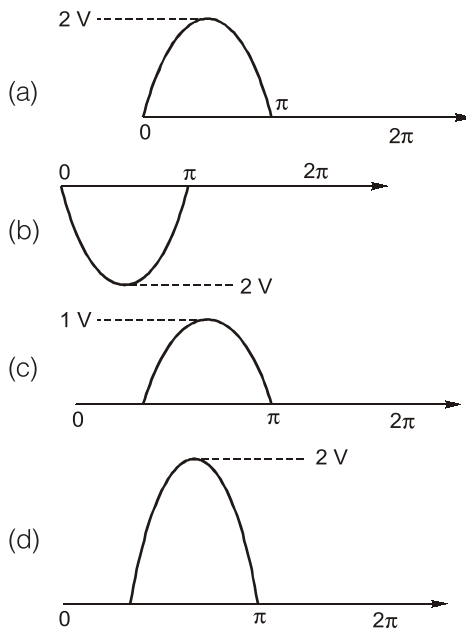

- Q.6** A diode is very useful for rectifier circuits due to its
- (a) ability to conduct current only in one direction
 - (b) ability to give current in both directions
 - (c) zero resistance in both directions
 - (d) none of these

- Q.7** In the circuit shown below, if $e_1 = 2\text{ V}$, $e_2 = 5\text{ V}$, $e_3 = 1\text{ V}$ and $E = 2\text{ V}$, then which one of the diodes will be conducting and what will be the e_0 ?

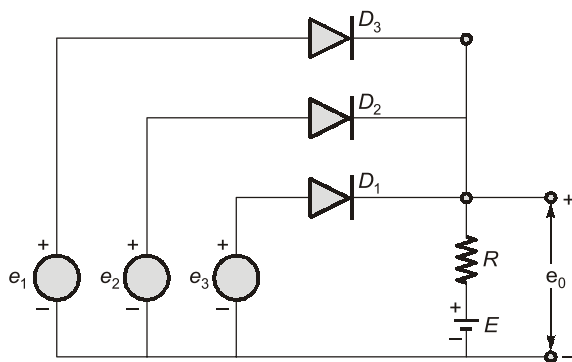

- (a) $D_3 : 1\text{ V}$
- (b) $D_1 : 2\text{ V}$
- (c) $D_2 : 5\text{ V}$
- (d) $D_1 : 5\text{ V}$

- Q.8** Assuming diode in the circuit is ideal one. Find the current and voltage shown in the figure.

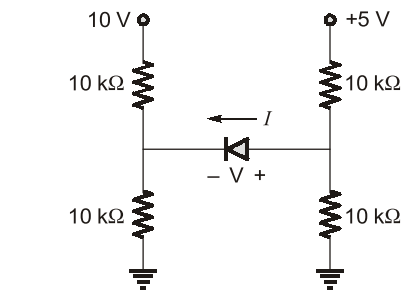

- (a) $0\text{ mA}, 2\text{ V}$
- (b) $0\text{ mA}, -2.5\text{ V}$
- (c) $1\text{ mA}, 2\text{ V}$
- (d) $1\text{ mA}, 2.5\text{ V}$

- Q.9** Consider the following statements regarding the circuit given in the figure, where the output voltage is constant:

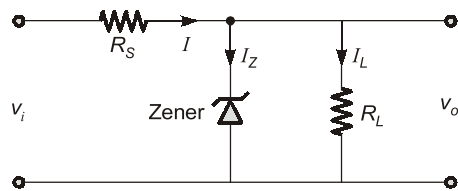

1. $v_i >$ the voltage at which the Zener breaks down.
 2. $I_L <$ the difference between I and I_Z , the current at which the Zener breaks down.
 3. $R_S <$ the Zener nominal resistance.
- Of these statements:
- (a) 1, 2 and 3 are correct
 - (b) 1 and 2 are correct
 - (c) 2 and 3 are correct
 - (d) 1 and 3 are correct

- Q.10** The ideal characteristics of a voltage stabilizer is

- (a) constant output voltage with low internal resistance
- (b) constant output current with low internal resistance
- (c) constant output voltage with high internal resistance
- (d) constant internal resistance with variable output voltage

ANSWERS KEY

- 1. (c) 2. (c) 3. (a) 4. (b) 5. (c)
- 6. (a) 7. (c) 8. (b) 9. (b) 10. (a)

HINTS & EXPLANATIONS

1. (c)

The given circuit is a positive clipper.

For $V_i > V_R$, the diode is forward biased and acts as short-circuit.

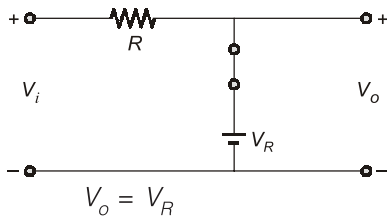

For $V_i < V_R$, diode is reverse-biased and acts as open-circuit.

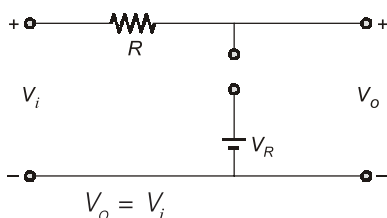

Hence,
$$V_o = \begin{cases} V_R & \text{for } V_i \geq V_R \\ V_i & \text{for } V_i < V_R \end{cases}$$

2. (c)

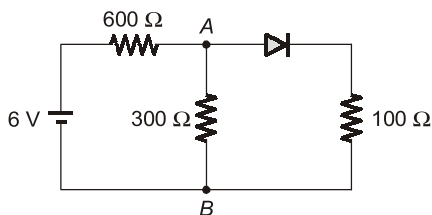

Calculating Thevenin equivalent across terminals A-B,

$$V_{AB} = \frac{6 \times 300}{300 + 600} = 2 \text{ V}$$

$$R_{AB} = \frac{600 \times 300}{600 + 300} = 200 \Omega$$

Since, the diode is forward-biased, the equivalent circuit can be drawn as below:

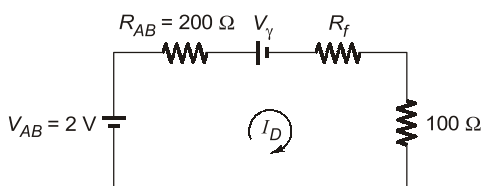

$$I_D = \frac{V_{AB} - V_Y}{200 + R_f + 100}$$

where, V_Y is the cut-in voltage and R_f is the forward resistance of diode,

$$6.7 \times 10^{-3} = \frac{2 - V_Y}{300 + R_f}$$

The above condition is satisfied for option (c):

$$V_Y = 0 \text{ and } R_f = 0$$

3. (a)

For $V_i > V_Y + V_{Z1} = 5.6 \text{ V}$, Zener diode Z_1 will be forward-bias and Z_2 will be in break-down region.

Hence, $V_o = V_Y + V_{Z1} = 5.6 \text{ V}$; for $V_i > 5.6 \text{ V}$

For $V_i < -V_Y - V_{Z2} = -5.6 \text{ V}$, Z_2 will be forward-bias and Z_1 will be in break-down region. Hence,

$$V_o = -V_Y - V_{Z2} = -5.6 \text{ V}; \text{ for } V_i < -5.6 \text{ V}$$

For $-5.6 \text{ V} \leq V_i \leq 5.6 \text{ V}$, the reverse-biased Zener diode is not in break-down region and hence, doesn't conduct current

$$V_o = V_i \text{ for } -5.6 \leq V_i \leq 5.6 \text{ V}$$

$$V_o = V_i \text{ for } |V_i| \leq 5.6 \text{ V}$$

4. (b)

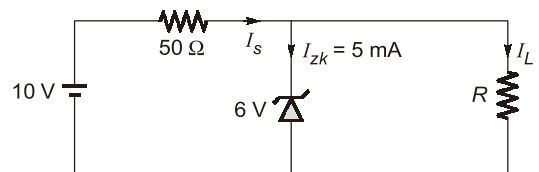

In the above regulator circuit,

$$I_s = \frac{10 - 6}{50} = 0.08 \text{ A} = 80 \text{ mA}$$

When the minimum current (knee current passes through the diode), then maximum current passes through load resistance R . Hence,

$$I_{L(\text{max})} = I_s - I_{zk} = 80 \text{ mA} - 5 \text{ mA}$$

$$\frac{6}{R_{s(\text{min})}} = 75 \times 10^{-3} \Rightarrow R_{s(\text{min})} = 80 \Omega$$

5. (c)

From the given V - I characteristics of diode,

$$V_Y = 0.5 \text{ V}, R_f = 300 \Omega$$

In the given circuit, diode is forward-biased for $V_i > 0.5 \text{ V}$. Hence, the equivalent circuit can be drawn as below:

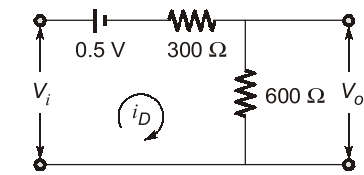

$$i_D = \frac{V_i - 0.5}{900} \text{ A}$$

$$V_o = 600i_D = 600 \left(\frac{V_i - 0.5}{900} \right) = \frac{2}{3} (V_i - 0.5)$$

For $V_i < 0.5 \text{ V}$, diode is reverse-biased and acts as open-circuit. Hence,

$$V_o = 0$$

$$V_o = \begin{cases} \frac{2}{3}(V_i - 0.5) & ; \text{ for } V_i > 0.5 \text{ V} \\ 0 & ; V_i < 0.5 \text{ V} \end{cases}$$

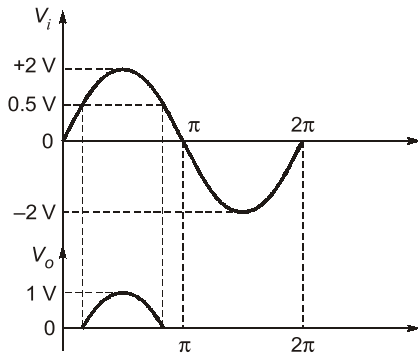

6. (a)

The diodes allows the current only in one direction and block the current flow into the other. The above property of diode is used to convert bidirectional voltage into unidirectional voltage in a rectifier.

7. (c)

If either of diodes D_1 or D_3 is conducting, then D_2 will also conduct and two voltages will try to superimpose at e_o which is violation of Kirchoff's law.

When diode D_2 conducts, $e_o = 5 \text{ V}$ and both the diodes D_1 and D_3 are reverse-biased. Hence, D_2 conducts : $e_o = 5 \text{ V}$

8. (b)

Using the voltage division rule, Voltage on n -side of diode,

$$V_n = 10 \left(\frac{10}{10 + 10} \right) = 5 \text{ V}$$

Voltage on p -side of diode,

$$V_p = 5 \left(\frac{10}{10 + 10} \right) = 2.5 \text{ V}$$

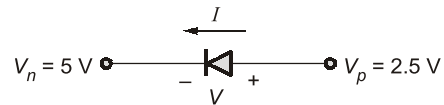

Since, $V_n > V_p$. Hence, the diode is reverse-biased and $I = 0$. The diode acts as open-circuit.

$$\therefore V = 2.5 - 5 = -2.5 \text{ V}$$

9. (b)

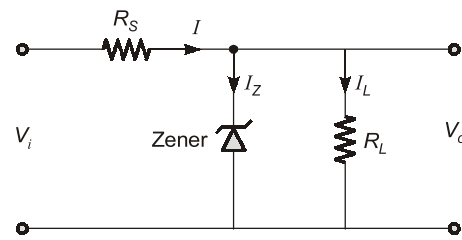

- $V_i = V_z + IR_s$. Hence, $V_i > V_z$. Therefore, statement 1 is correct.
- We have, $I = I_z + I_L$
Here, $I_{L(\max)} = I - I_{zk}$, where I_{zk} is the current at which Zener break-down.
 $I_{L(\min)} = I - I_{z(\max)}$
Therefore, $I_L < I - I_{zk}$
Hence, statement 2 is correct.
- The Zener nominal resistance is very small and less than the resistance R_s . Hence, statement 3 is incorrect.

10. (a)

Voltage stabilizer must provide a constant output voltage.

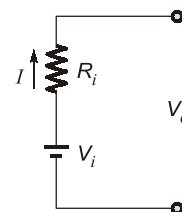

$$V_o = V_i - IR_i$$

For $V_o \approx V_i$, R_i should be very low.

Hence, the voltage stabilizer must have constant output voltage with low internal resistance.



CONVENTIONAL BRAIN TEASERS

Q.1 A light-emitting diode (LED) has a greater forward voltage drop than that of common signal diode. A typical LED can be modeled as a constant forward voltage drop $v_D = 1.6\text{ V}$. Its luminous intensity I_V varies directly with forward current and is described by $I_V = 40i_D$ millicandela (mcd).
A series circuit consists of a LED, a current-limiting resistor R , and a 5-V DC source V_S . Find the value of R such that the luminous intensity is 1 mcd.

1. (Sol.)

With a 5 V DC source, LED is forward-biased and can be modelled as a constant forward voltage drop $V_D = 1.6\text{ V}$. The equivalent circuit can be drawn as below:

$$\therefore i_D = \frac{5 - 1.6}{R}$$

The luminous intensity, I_V is defined as

$$I_V = 40i_D \text{ (mcd)}$$

$$\Rightarrow 1 \text{ mcd} = 40 \left(\frac{5 - 1.6}{R} \right)$$

$$\Rightarrow R = 136 \Omega$$

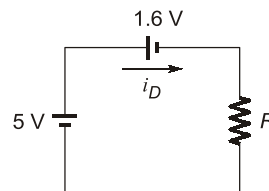

Q.2 Determine the maximum and the minimum input voltages that can be regulated by the Zener diode of circuit shown in figure. Take $V_{out} = 5.1\text{ V}$, at $I_z = 49\text{ mA}$, $I_{zk} = 1\text{ mA}$, $R_z = 7\ \Omega$ at I_z power dissipation = 1 Watt.

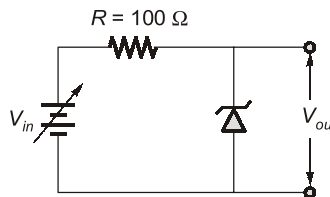

2. (Sol.)

The equivalent circuit with Zener diode in breakdown region can be drawn as below:

Given: $V_{out} = 5.1\text{ V}$ at $I_z = 49\text{ mA}$

At $I_{zk} = 1\text{ mA}$, the output voltage is

$$V_{out} = 5.1\text{ V} - (I_z - I_{zk}) R_z$$

$$V_{out} = 5.1 - (49 - 1) \times 7 \times 10^{-3}$$

$$V_{out} = 4.76\text{ V}$$

Hence, the minimum voltage that can be regulated is

$$V_{in(\text{min})} = I_{zk} \times R + V_{out}$$

$$V_{in(\text{min})} = 1 \times 10^{-3} \times 100 + 4.76 = 4.86\text{ V}$$

To find the maximum input voltage, we first calculate the maximum Zener current. For power dissipation of 1 Watt,

